

BC[0,1] = BC_L3_S[0,1] (control to PCI-3 FPGA)
 BC[2,3] = L1_BUSY, ERROR (control to PCI-3/J4)
 BC[4,5] = L2_BUSY, ERROR (control to PCI-3/J4)

27 Mar 01 - add BC[5:0], synchronize with 6 Mar STC_C
 27 Feb 01 - Second release - many (small) changes
 1 Feb 01 - feed clock through control; add term
 29 Jan 01 - First release

Boston University	
Electronics Design Facility	
Title D0 SILICON TRIGGER CARD	
Size Custom	Document Number SCHEMATIC TOP
Date: Monday, April 23, 2001	Sheet 1 of 20
	Rev A

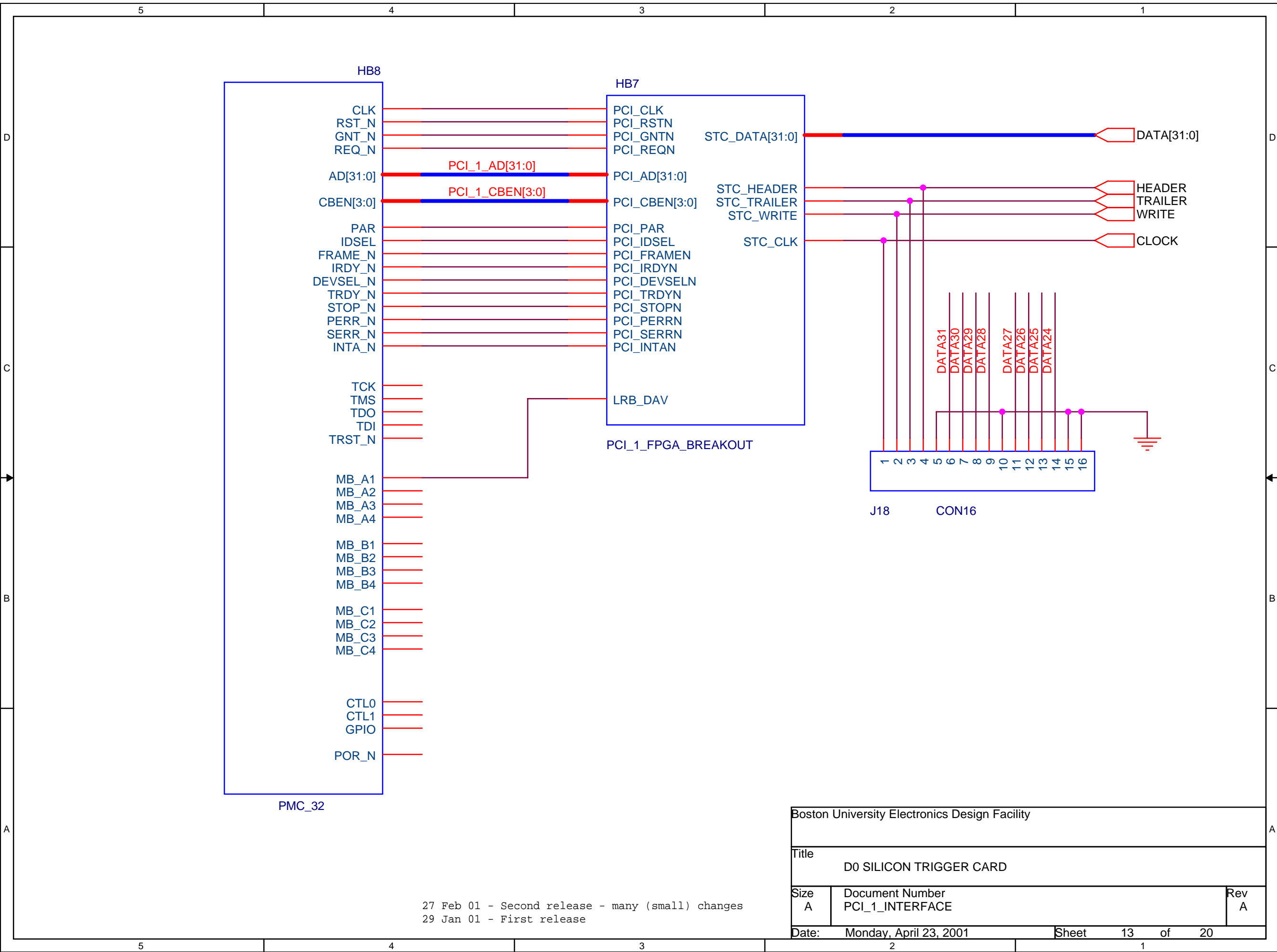

27 Feb 01 - Second release - many (small) changes
 29 Jan 01 - First release

Boston University Electronics Design Facility		
Title D0 SILICON TRIGGER CARD		
Size A	Document Number PCI_1_INTERFACE	Rev A
Date: Monday, April 23, 2001	Sheet 13	of 20

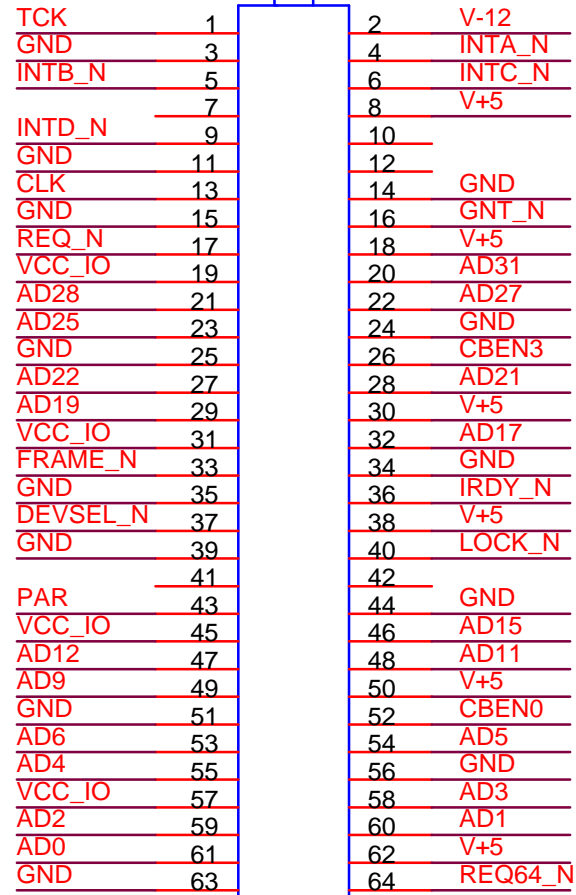

HEADER 32x2/SM

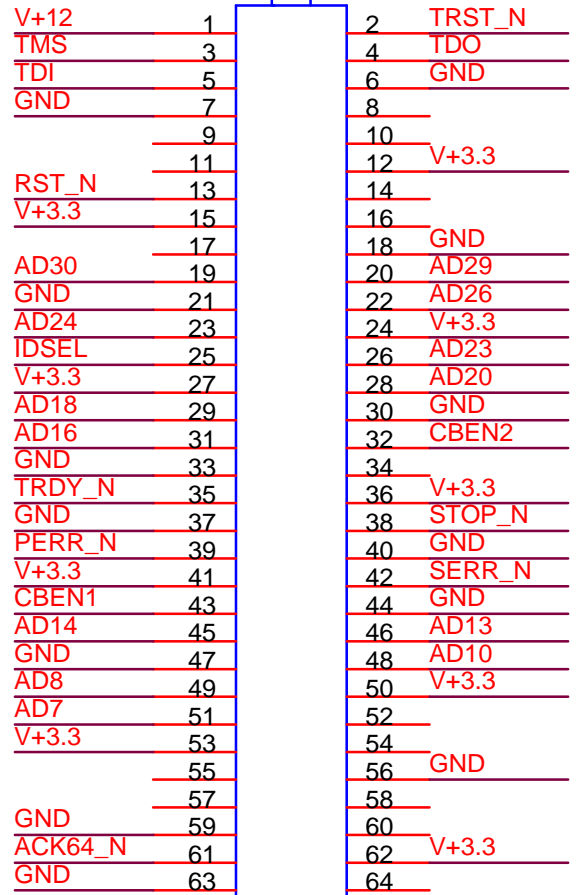

HEADER 32x2/SM

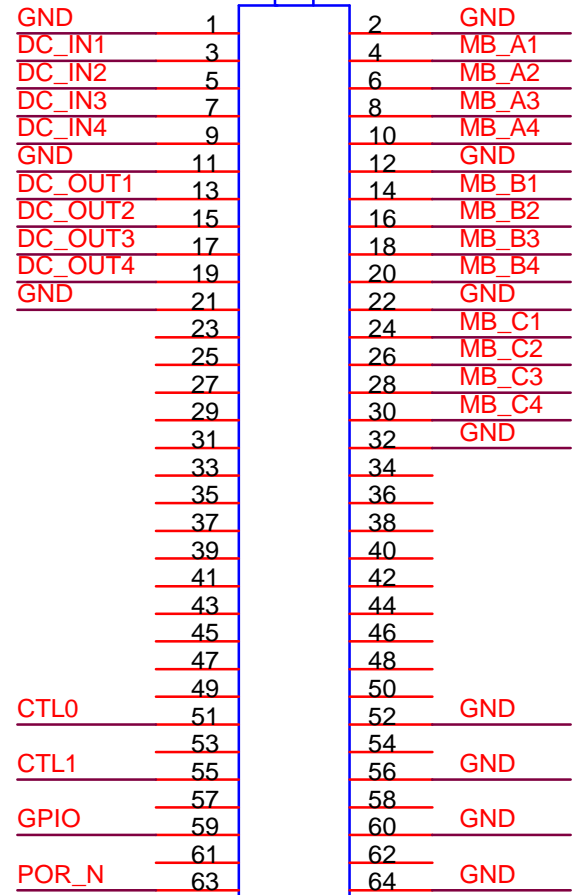

HEADER 32x2/SM

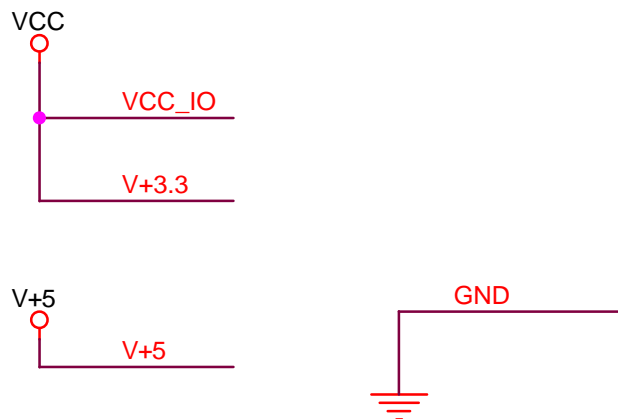
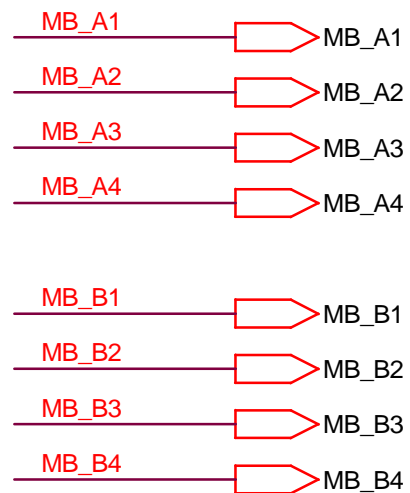
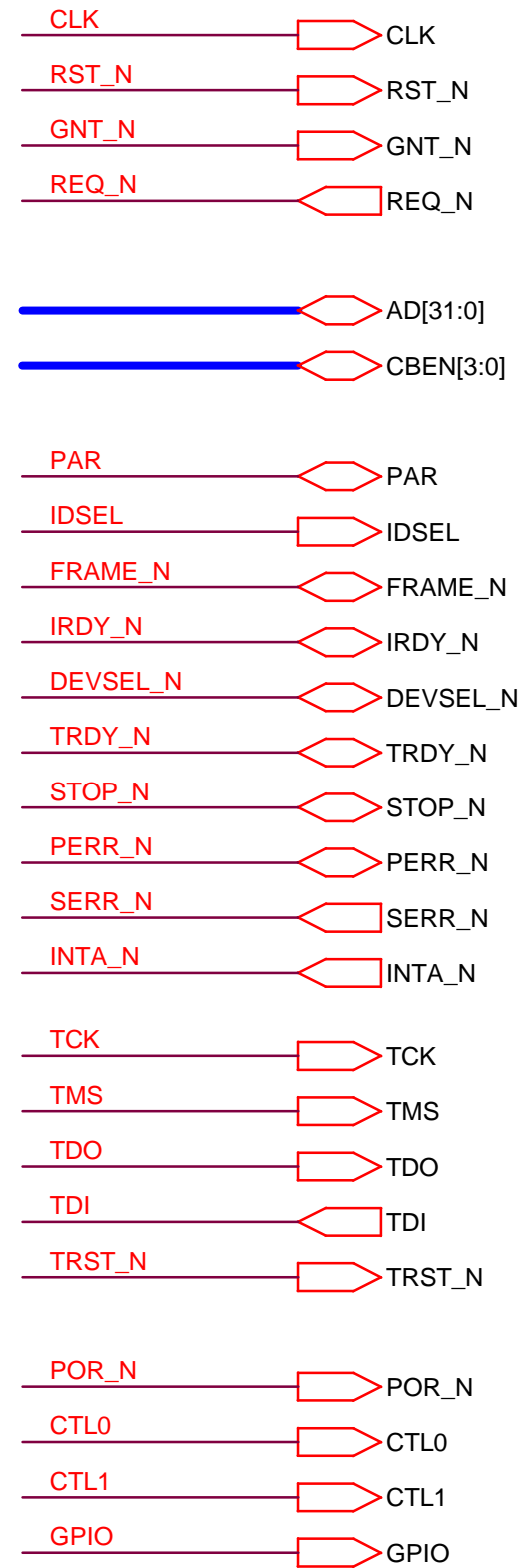

27 Feb 01 - Second release - many (small) changes
 29 Jan 01 - First release

Title		
D0 SILICON TRIGGER CARD		
Size	Document Number	Rev
A	PCI Bus (PMC) Connectors (typical of 3)	A
Date:	Monday, April 23, 2001	Sheet 15 of 20

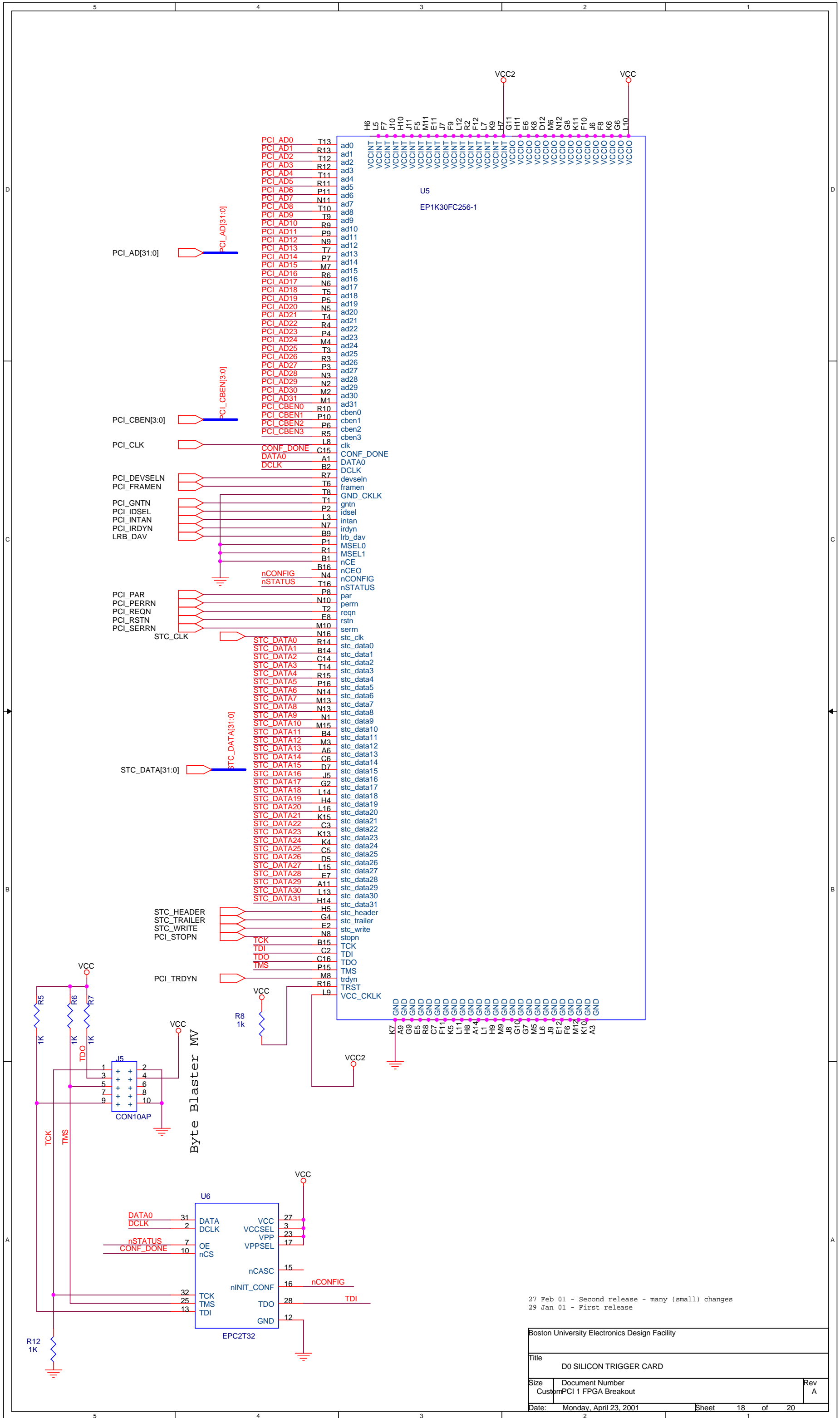

27 Feb 01 - Second release - many (small) changes
 29 Jan 01 - First release

Boston University Electronics Design Facility		
Title D0 SILICON TRIGGER CARD		
Size	Document Number	Rev
Custom	PCI 1 FPGA Breakout	A
Date:	Monday, April 23, 2001	Sheet 18 of 20

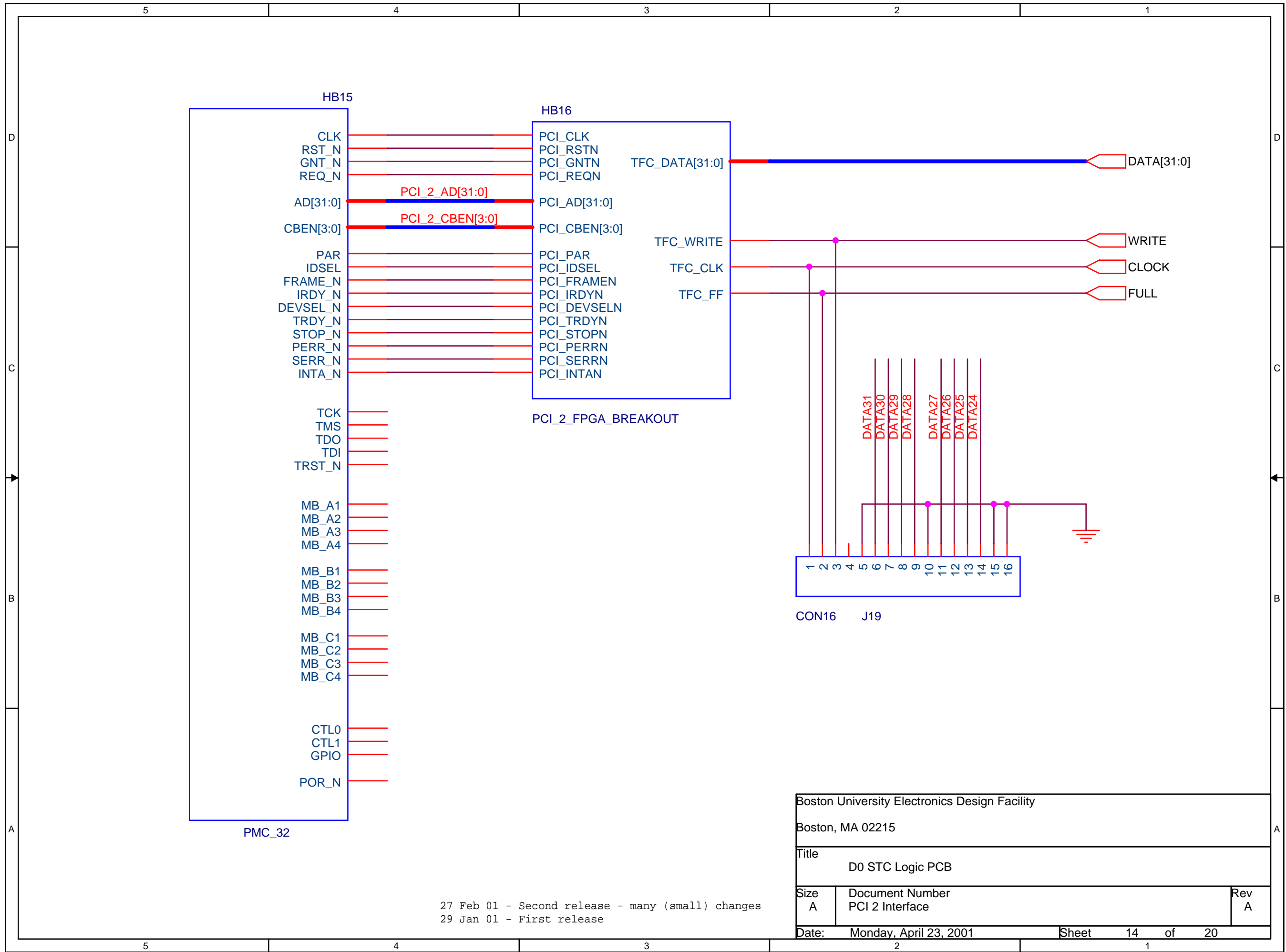

27 Feb 01 - Second release - many (small) changes
 29 Jan 01 - First release

Boston University Electronics Design Facility		
Boston, MA 02215		
Title D0 STC Logic PCB		
Size A	Document Number PCI 2 Interface	Rev A
Date: Monday, April 23, 2001	Sheet 14	of 20

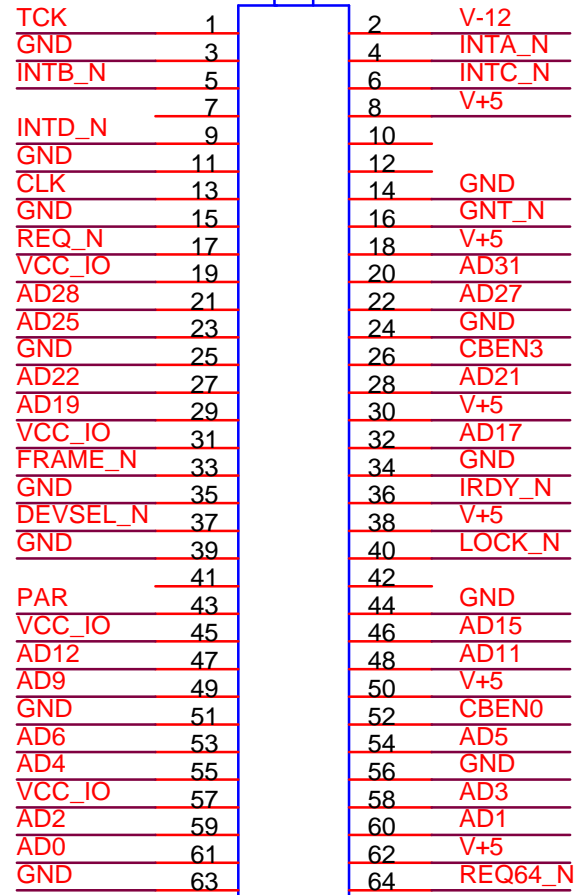

HEADER 32x2/SM

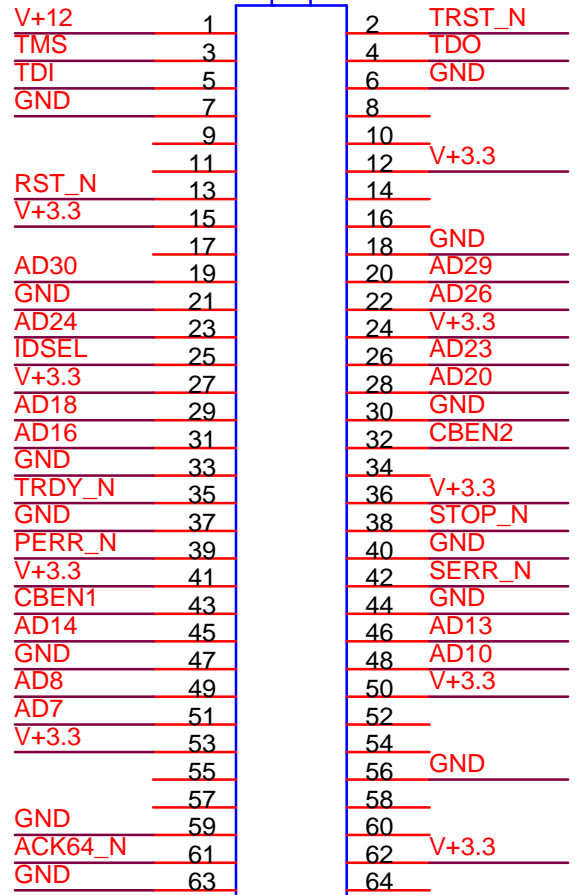

HEADER 32x2/SM

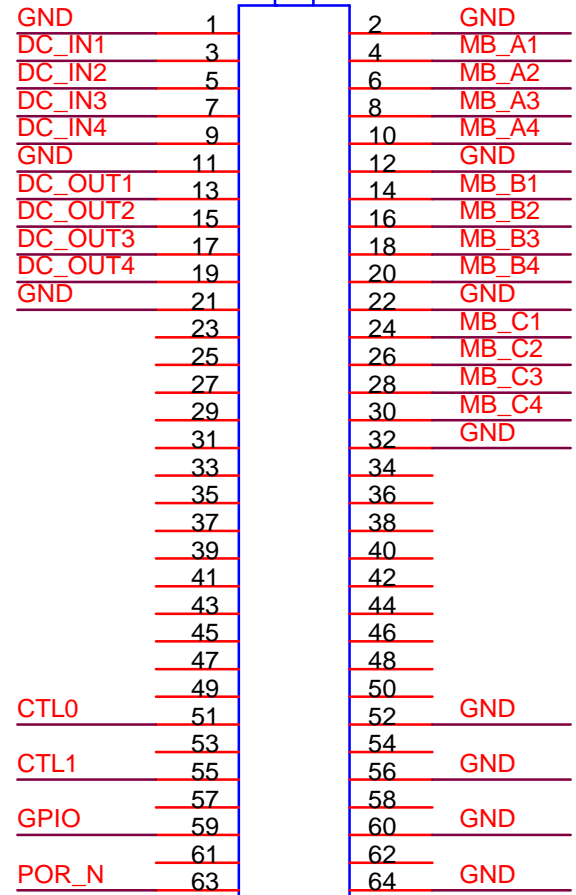

HEADER 32x2/SM

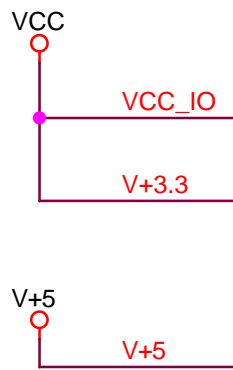
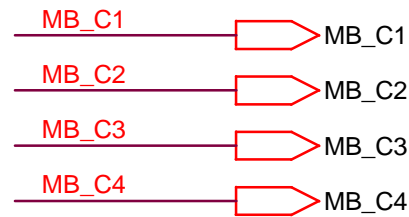
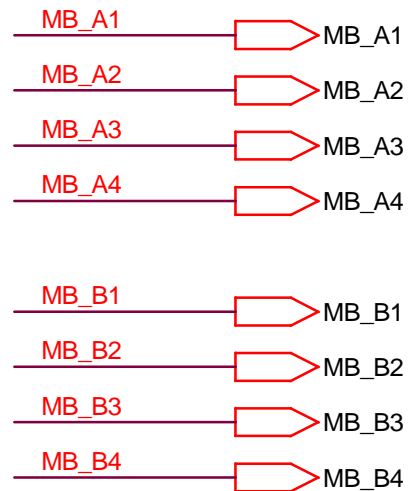
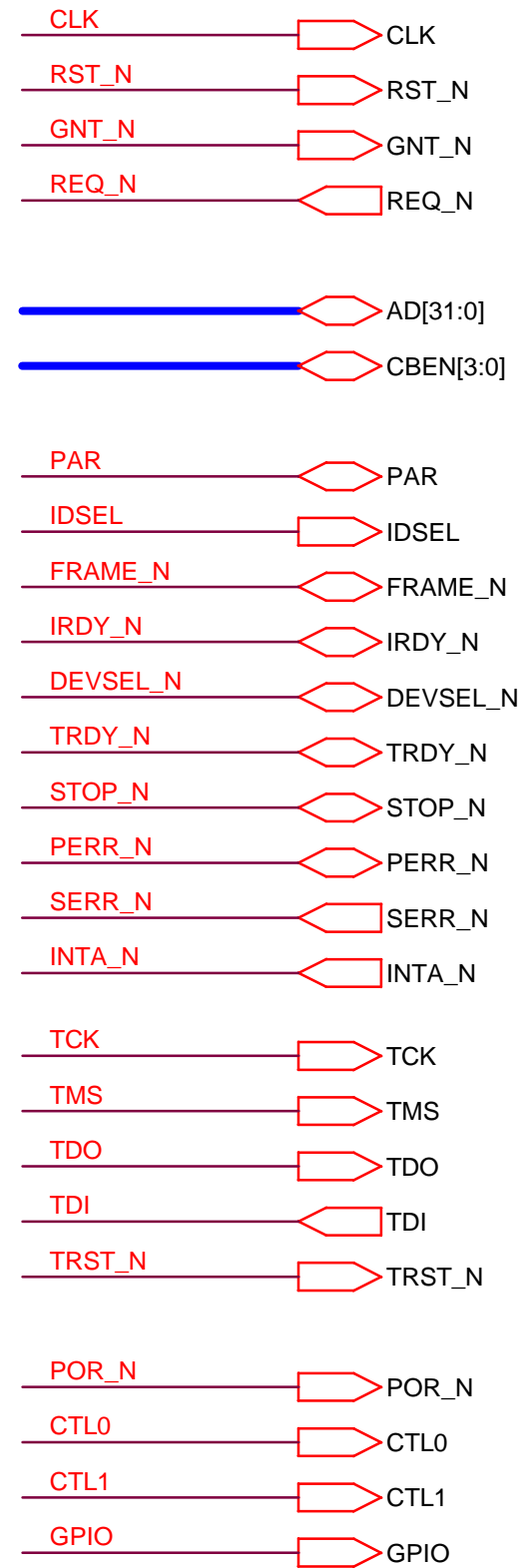

27 Feb 01 - Second release - many (small) changes
 29 Jan 01 - First release

Title		
D0 SILICON TRIGGER CARD		
Size	Document Number	Rev
A	PCI Bus (PMC) Connectors (typical of 3)	A
Date:	Monday, April 23, 2001	Sheet 8 of 20

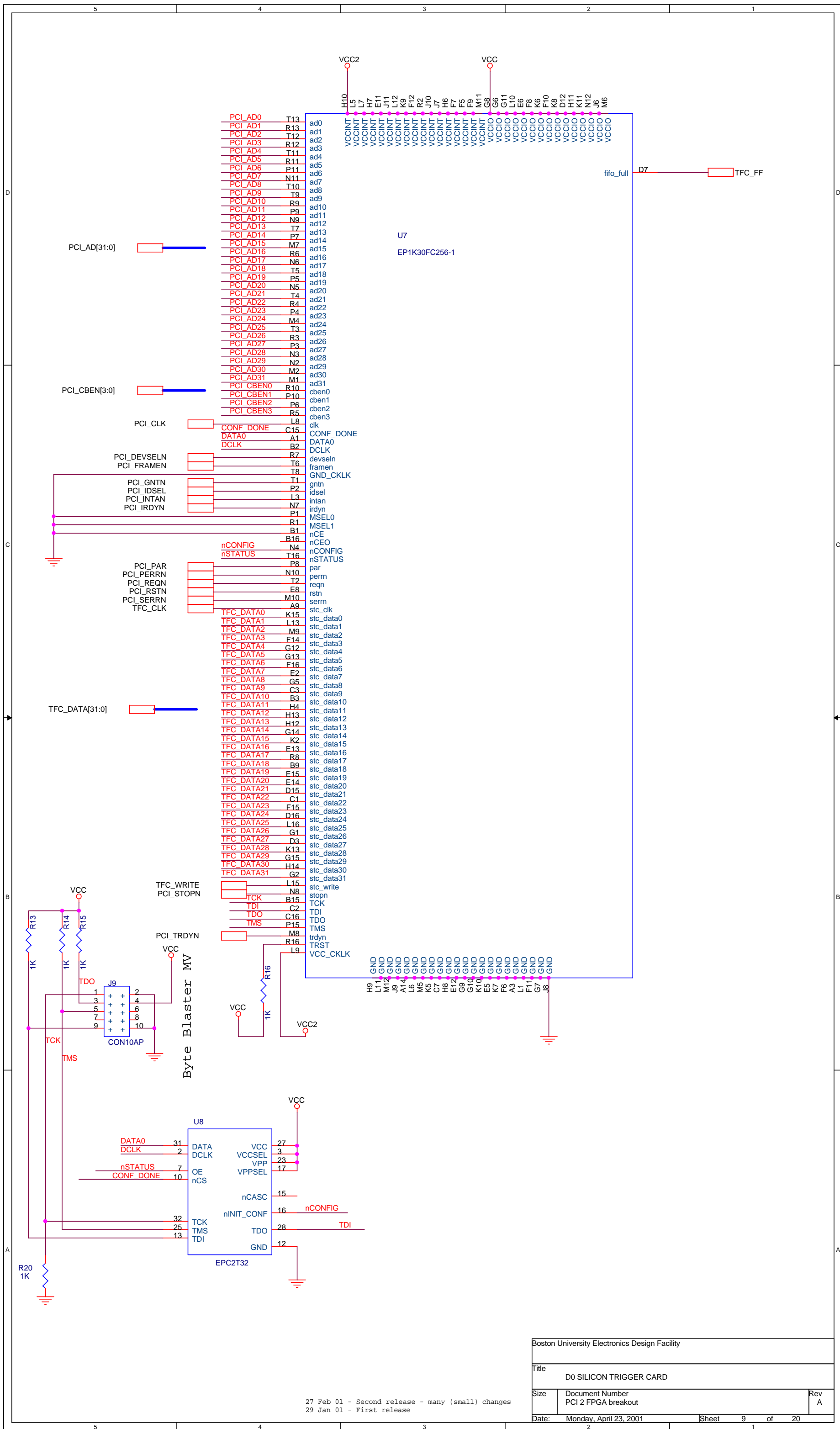

Boston University Electronics Design Facility		
Title D0 SILICON TRIGGER CARD		
Size	Document Number PCI 2 FPGA breakout	Rev A
Date:	Monday, April 23, 2001	Sheet 9 of 20

27 Feb 01 - Second release - many (small) changes
 29 Jan 01 - First release

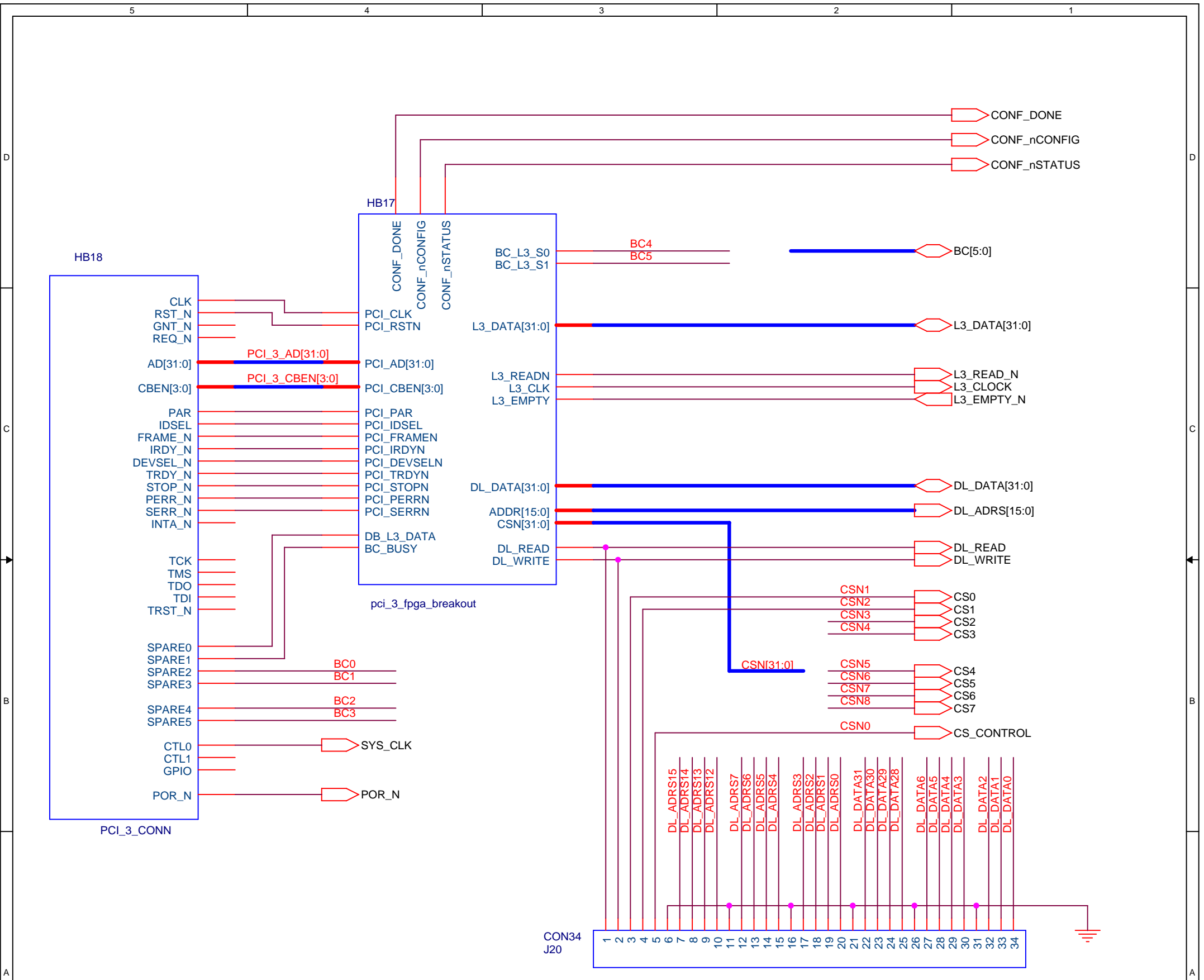

6 Mar 01 - Add BC[] stuff
 27 Feb 01 - Second release - many (small) changes
 29 Jan 01 - First release

Title		
D0 SILICON TRIGGER CARD		
Size	Document Number	Rev
	PCI 3 Interface	A
Date:	Monday, April 23, 2001	Sheet 1 of 1

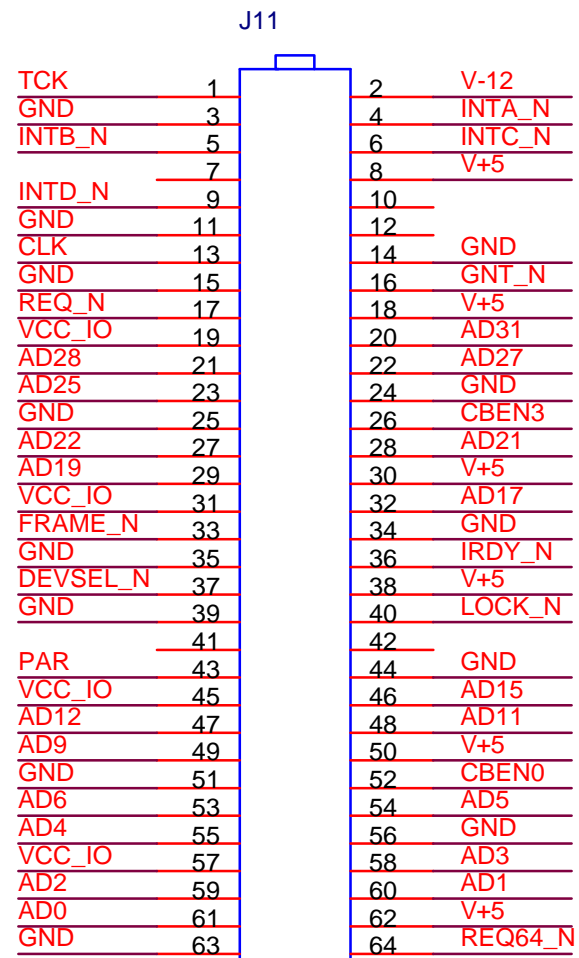

HEADER 32x2/SM

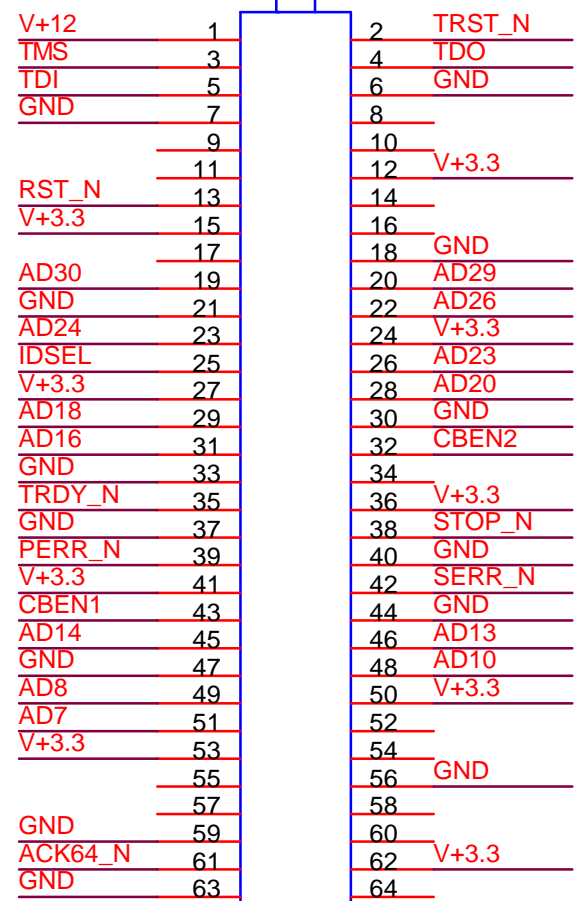

HEADER 32x2/SM

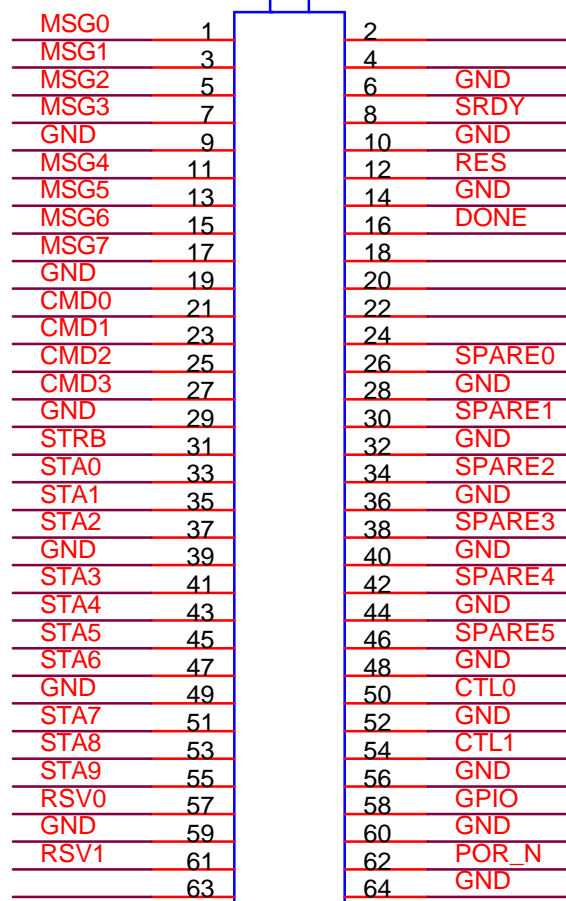

HEADER 32x2/SM

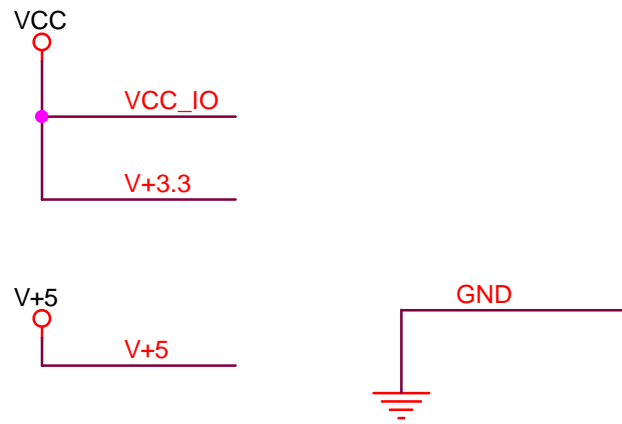
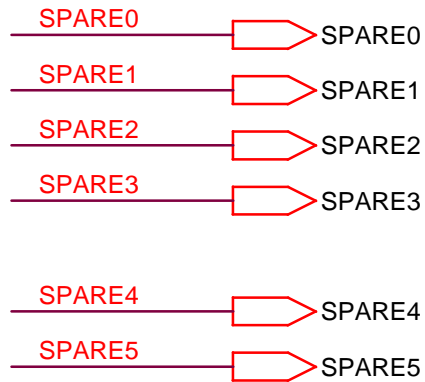
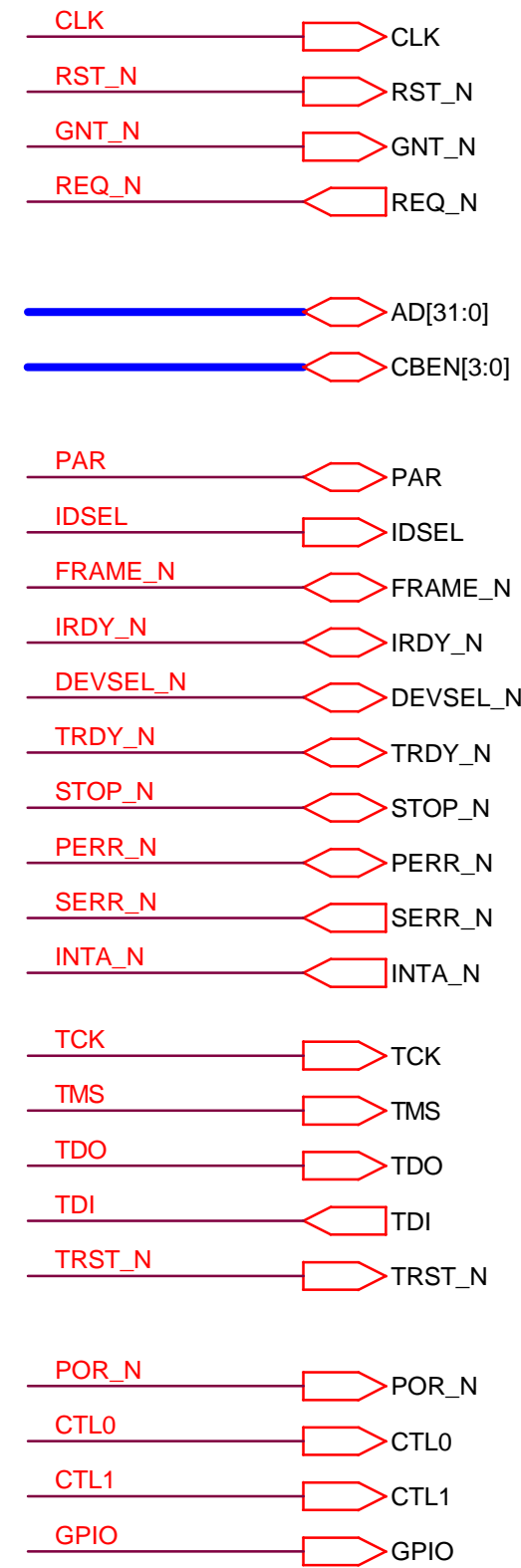

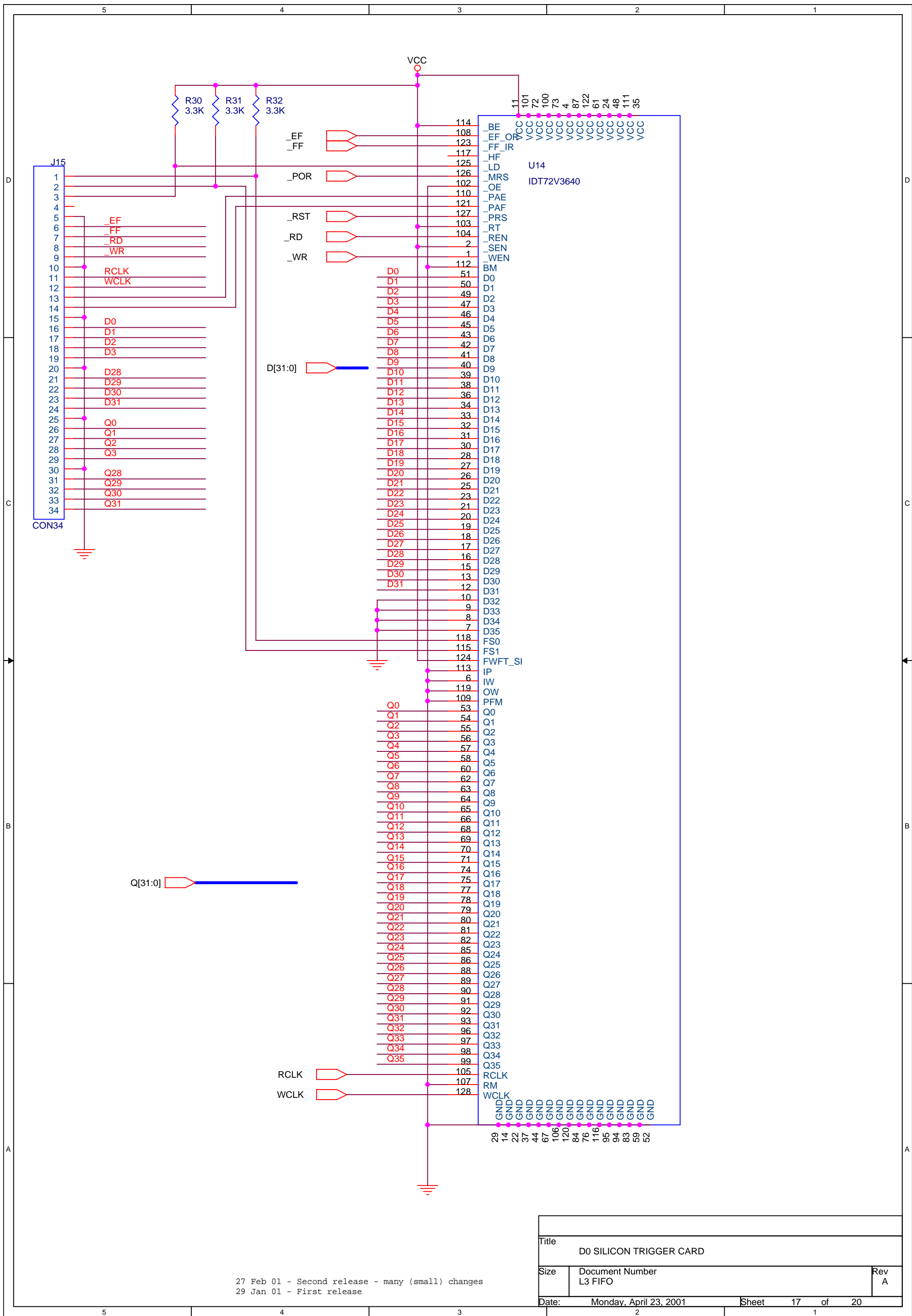

27 Feb 01 - Second release - many (small) changes
 29 Jan 01 - First release

Title		
D0 SILICON TRIGGER CARD		
Size	Document Number	Rev
	L3 FIFO	A
Date:	Monday, April 23, 2001	Sheet 17 of 20

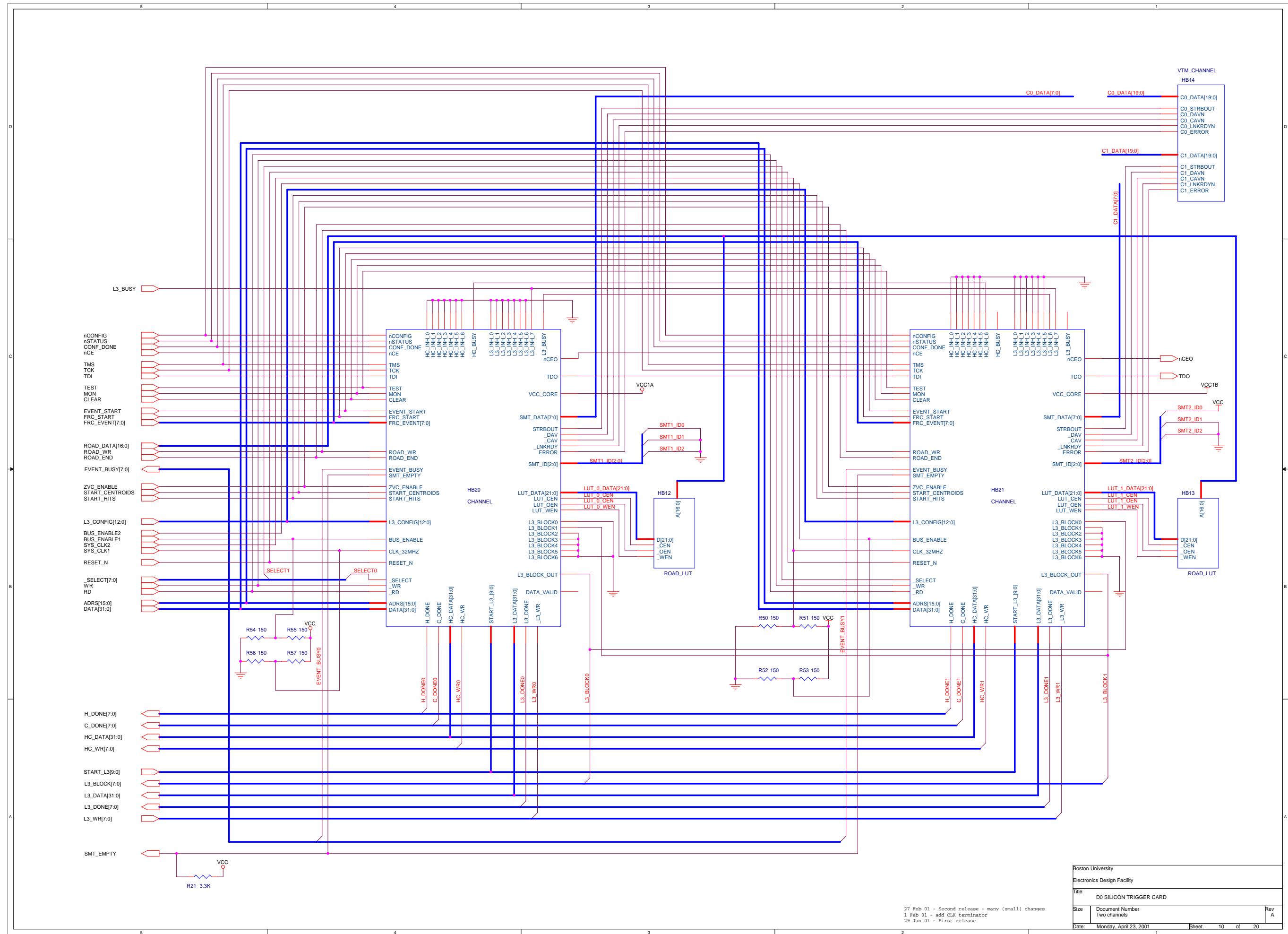

27 Feb 01 - Second release - many (small) changes
 1 Feb 01 - add CLK terminator
 29 Jan 01 - First release

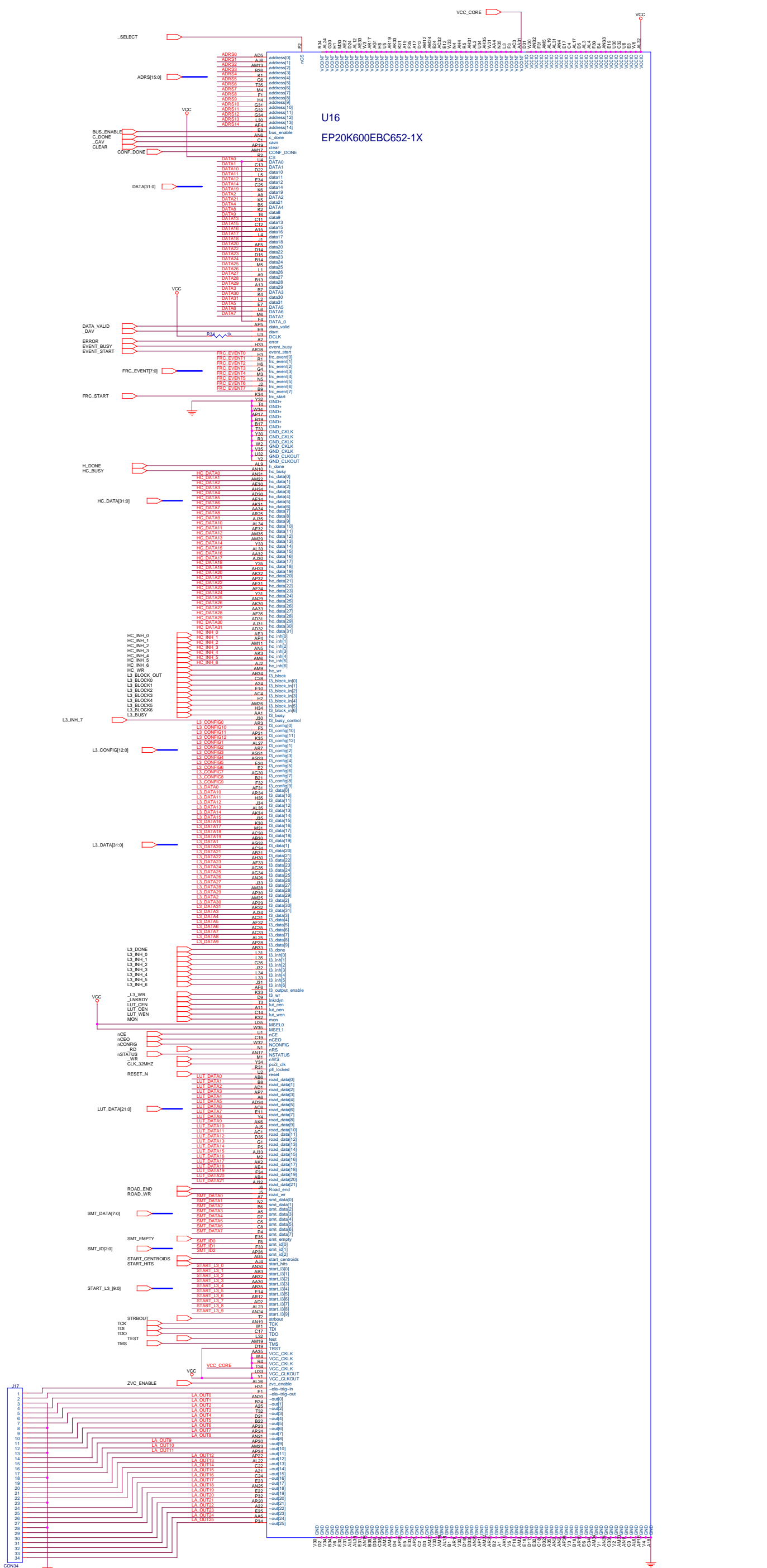

File	DO SILICON TRIGGER CARD	
Size	Document Number	Rev
Date	Monday, April 23, 2001	Sheet 6 of 20

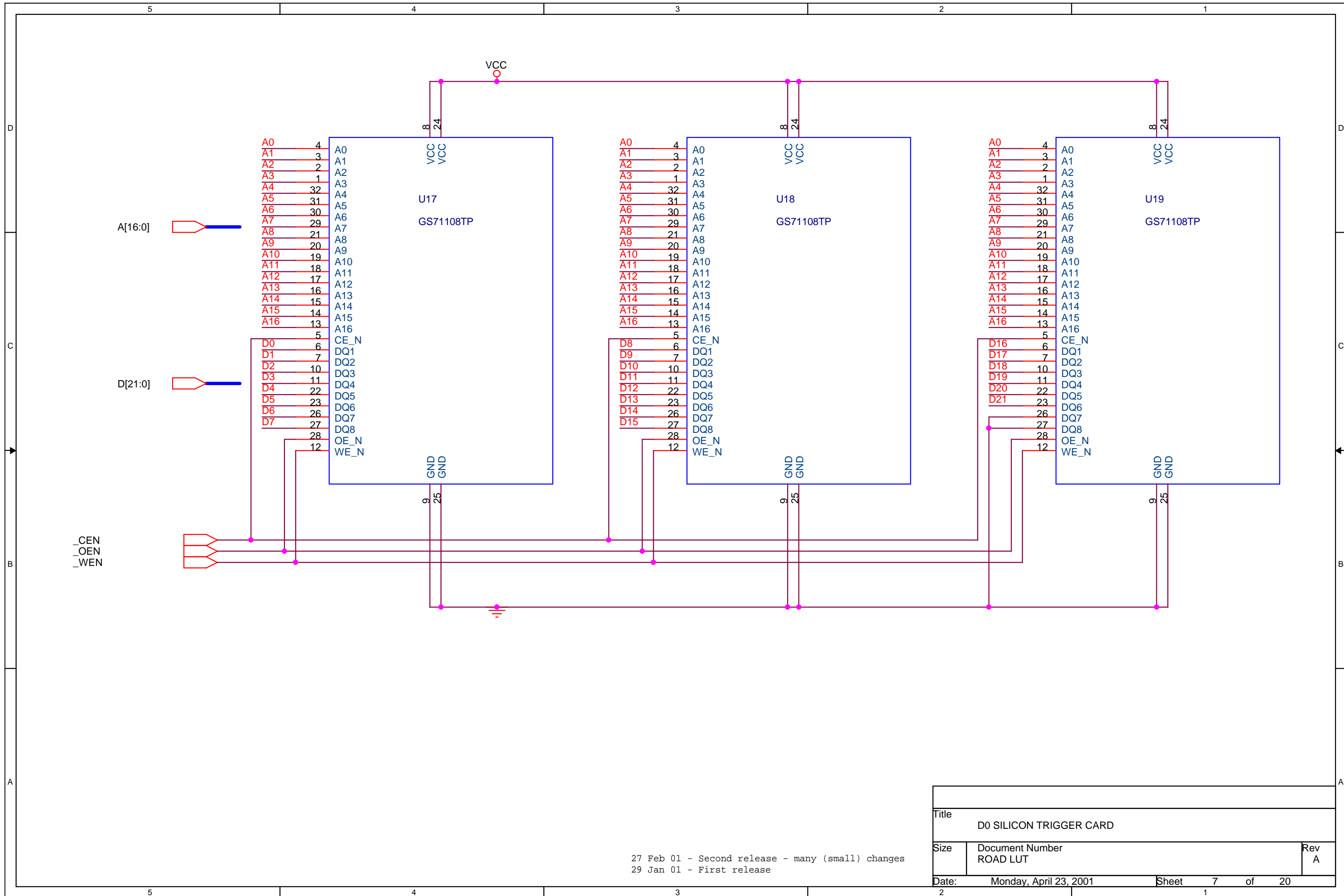

27 Feb 01 - Second release - many (small) changes
 29 Jan 01 - First release

Title		
D0 SILICON TRIGGER CARD		
Size	Document Number	Rev
	ROAD LUT	A
Date:	Monday, April 23, 2001	Sheet 7 of 20

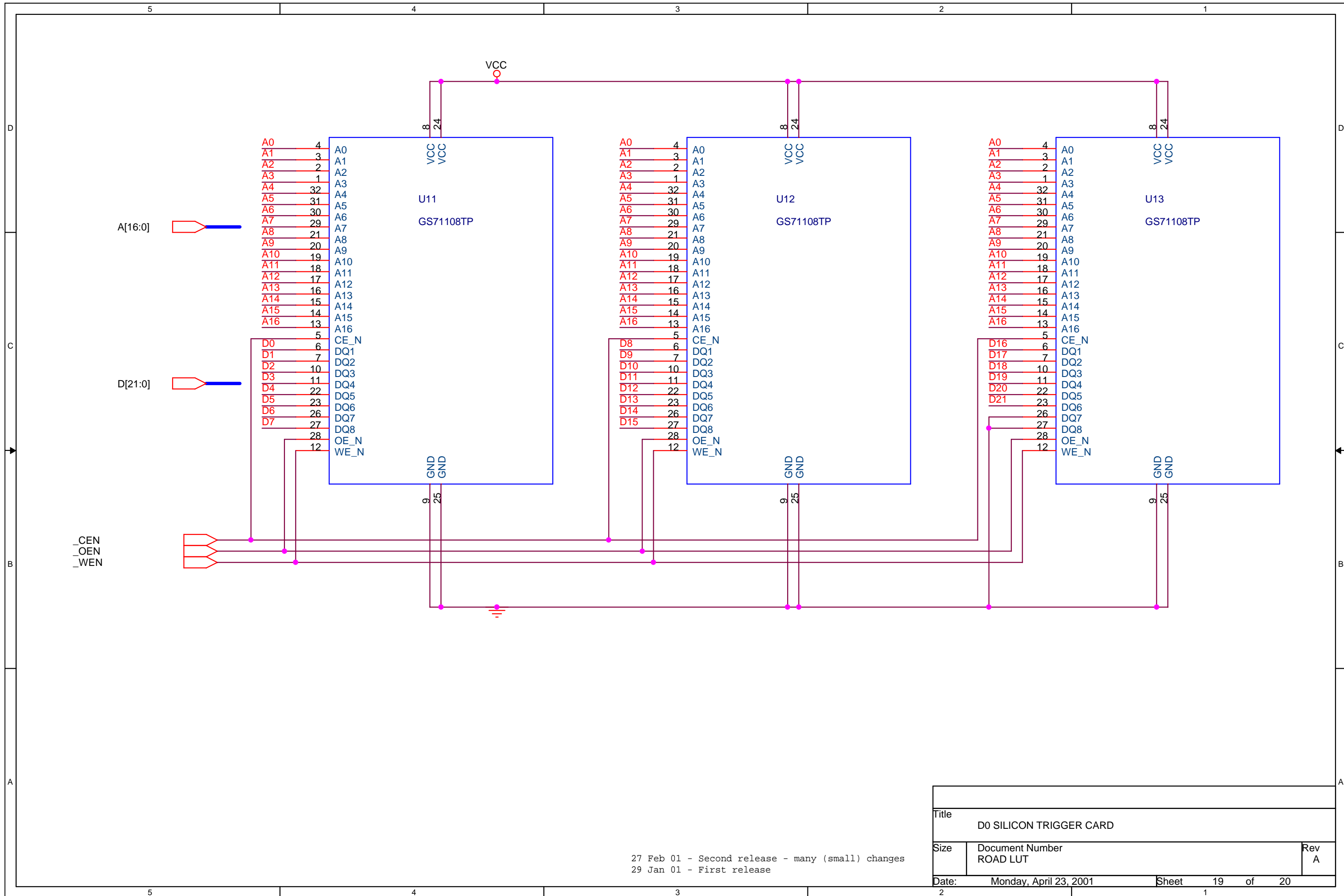

27 Feb 01 - Second release - many (small) changes
 29 Jan 01 - First release

Title		
D0 SILICON TRIGGER CARD		
Size	Document Number	Rev
	ROAD LUT	A
Date:	Monday, April 23, 2001	Sheet 19 of 20

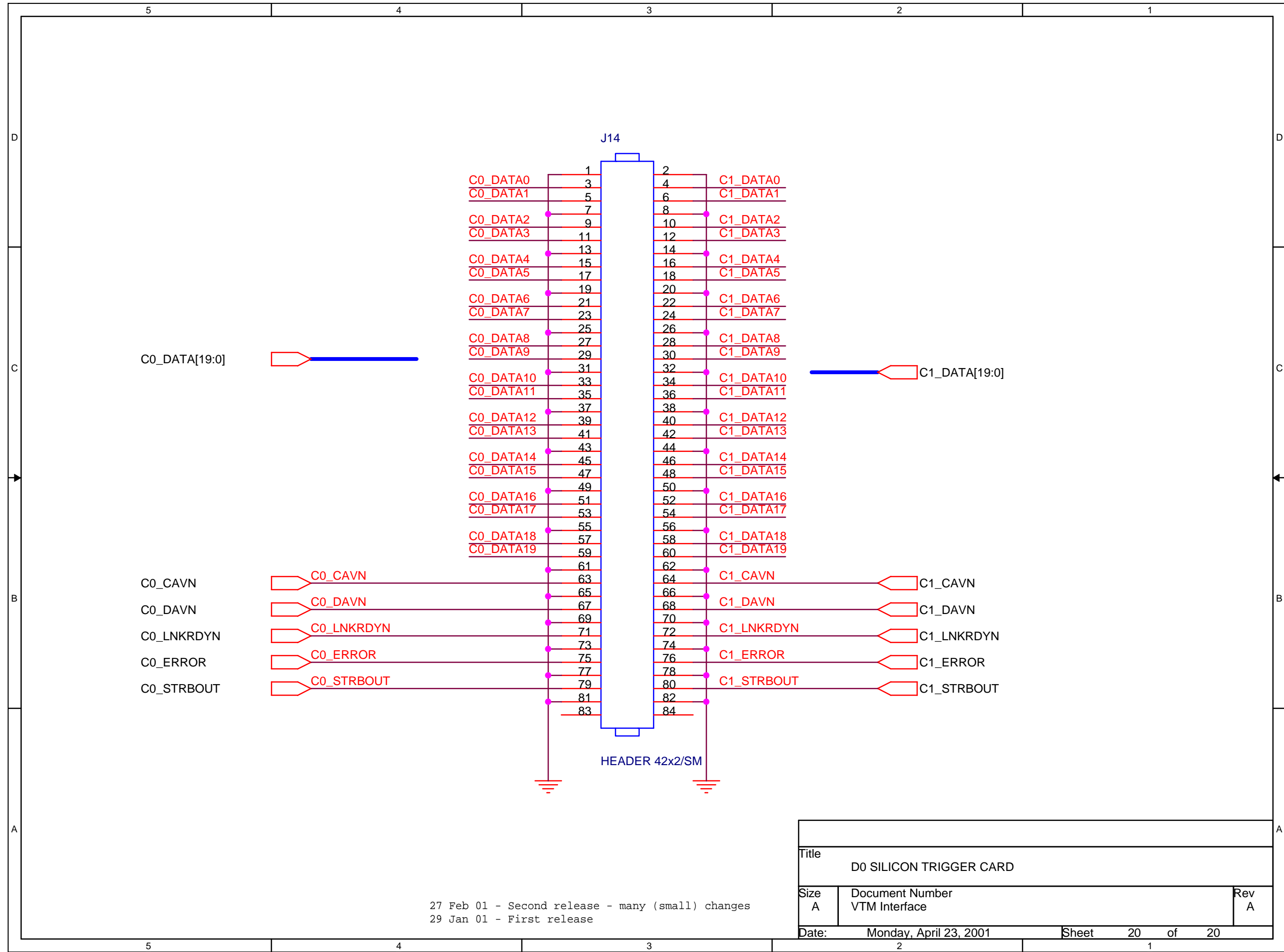

27 Feb 01 - Second release - many (small) changes
 29 Jan 01 - First release

Title		
D0 SILICON TRIGGER CARD		
Size	Document Number	Rev
A	VTM Interface	A
Date:	Monday, April 23, 2001	Sheet 20 of 20

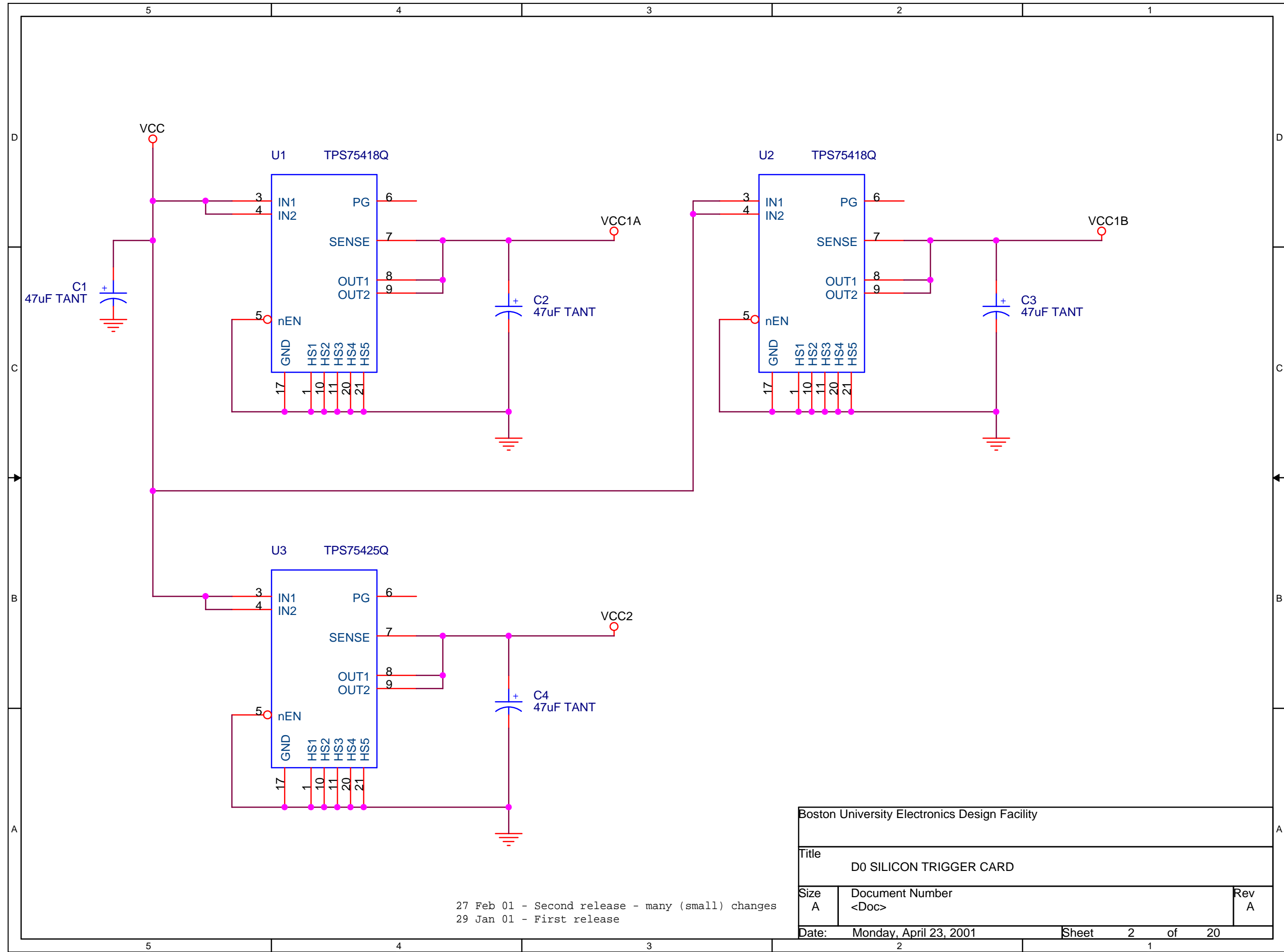

27 Feb 01 - Second release - many (small) changes
 29 Jan 01 - First release

Boston University Electronics Design Facility		
Title D0 SILICON TRIGGER CARD		
Size A	Document Number <Doc>	Rev A
Date: Monday, April 23, 2001	Sheet 2	of 20

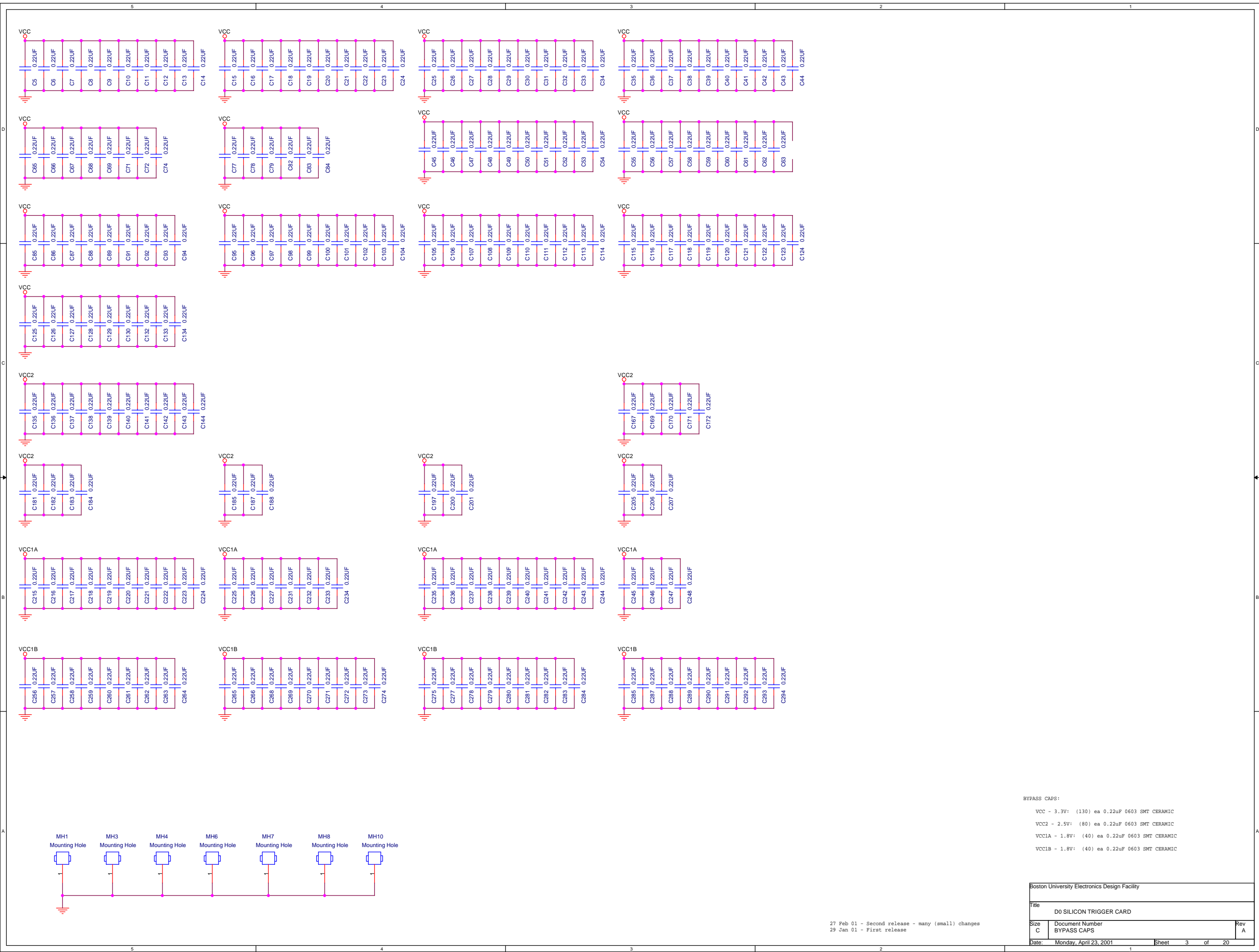

BYPASS CAPS:
 VCC - 3.3V: (130) ea 0.22uF 0603 SMT CERAMIC
 VCC2 - 2.5V: (80) ea 0.22uF 0603 SMT CERAMIC
 VCC1A - 1.8V: (40) ea 0.22uF 0603 SMT CERAMIC
 VCC1B - 1.8V: (40) ea 0.22uF 0603 SMT CERAMIC

Boston University Electronics Design Facility		
Title D0 SILICON TRIGGER CARD		
Size C	Document Number BYPASS CAPS	Rev A
Date: Monday, April 23, 2001	Sheet 3	of 20

27 Feb 01 - Second release - many (small) changes
 29 Jan 01 - First release